

ASNT1016 16:1 MUX-CMU

- 16 to 1 multiplexer (MUX) with integrated CMU (clock multiplication unit).
- PLL-based architecture featuring both counter and forward clocking modes.
- Supports multiple data rates in the 9.8-12.5Gb/s range.
- Optional CML high-speed clock input for a broad-band digital mode of operation.
- LVDS compatible parallel input data and low-speed clock buffers.
- High speed full rate clock output.
- Dual clock-divided-by-16 LVDS output buffers.
- Single +3.3V power supply.
- Industrial temperature range.
- Low power consumption of 660mW at 12.5Gbps.
- Available in custom 12x12-pin BGA package (10mm x 10mm).

DESCRIPTION

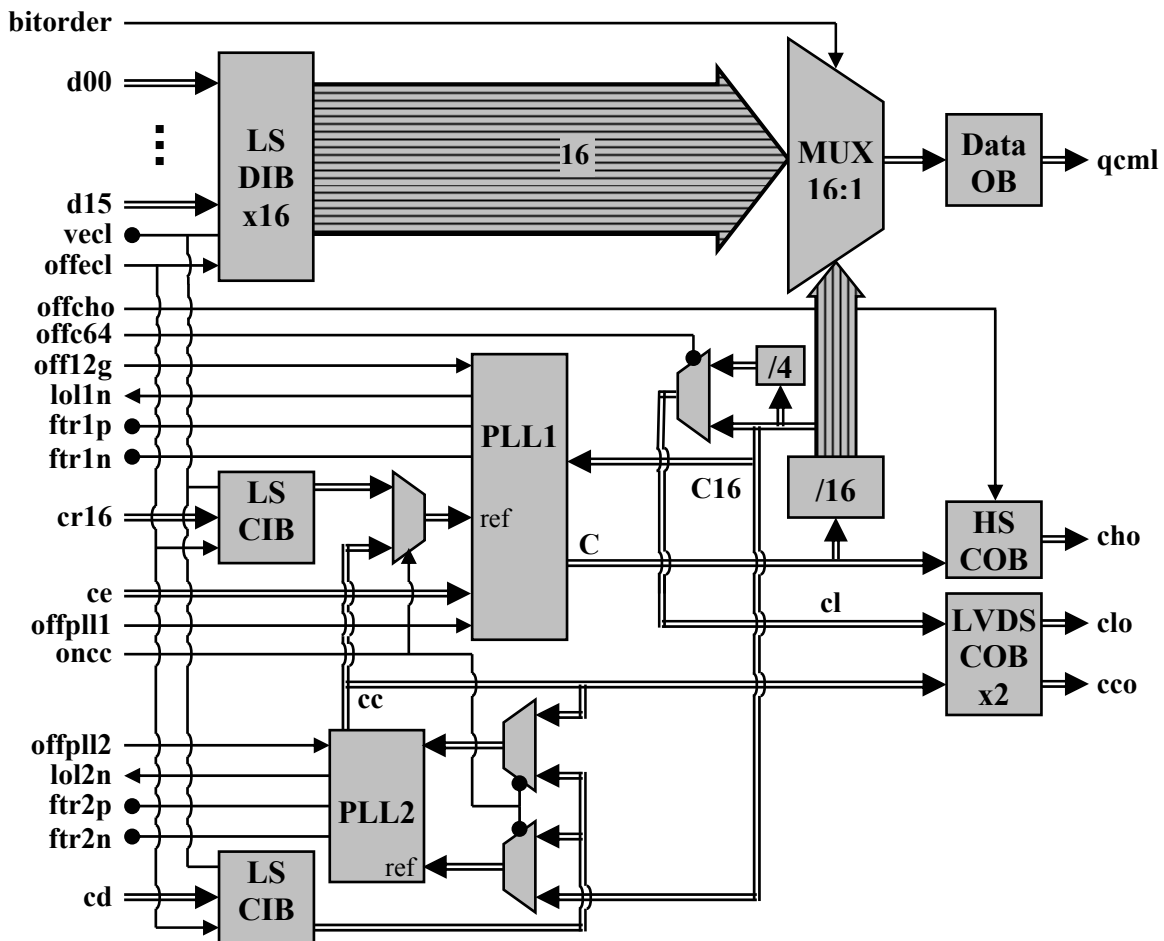

Fig. 1. Functional Block Diagram.



ASNT1016 is a low power and high-speed 16-to-1 multiplexer (MUX) with an internal clock multiplication unit (CMU). The MUX can function in CMU mode at data rates (f_{bit}) between 9.8Gb/s and 12.5Gb/s by utilizing its multiple on-chip full-rate VCOs, or as a broad-band digital MUX with data rates from DC to 14Gb/s.

The main function of ASNT1016 is to multiplex 16 parallel data channels running at a bit rate of $f_{bit}/16$ into a high speed serial bit stream running at a rate of f_{bit} . It provides a high-speed output data channel for point-to-point data transmission over a 50Ohm controlled-impedance media. The transmission media can be a printed circuit board or copper coaxial cables. The functional distance of the data transfer is dependent upon the attenuation characteristics of the transportation media and the degree of noise coupling to the signaling environment.

During normal operation, the serializer's low-speed input buffer (LS DIBx16) accepts external 16-bit wide parallel data words "d00"-"d15" through 16 differential inputs with LVDS interfaces tolerable to common-mode voltage deviation from "vee" to "vcc", and delivers them to the multiplexers core (MUX16:1) for serialization. By utilizing pin "bitorder", the serializer can designate either "d00" or "d15" as the MSB thus simplifying the interface between ASNT1016 and a preceding ASIC.

MUX16:1 serializes the data words with multiple divided down clock signals that are generated from the full rate clock "C" by the internal divider (/16). The divider also produces a clock divided-by-16 signal "C16" for use by both phase locked loops. "C" is synthesized by the main phase-locked loop (PLL1) that references either an external system level clock "cr16" delivered by one of the low speed clock input buffers (LS CIB) or the internal clock "cc" that is generated by the secondary phase locked loop (PLL2) in concert with a different external low speed clock "cd". Both "cr16" and "cd" must be 1/16 the frequency of the active full rate VCO in PLL1. PLL1 contains 2 full rate VCOs to cover the 9.8-12.5GHz range, which are selected utilizing the "off12g" control pin. PLL1 can be also disabled through "offpll1" control pin, in which case clock "C" must be provided externally through input "ce". This input can be either DC coupled utilizing a differential CML signal, or AC-coupled utilizing a single-ended (SE) signal applied to one of the differential pins.

ASNT1016 offers 3 different kinds of clocking modes. In the default state, PLL2 is turned off through pin "offpll2" and PLL1 is locked to the "clean" system clock "cr16".

In the forward clocking mode ("offpll2"=0 & "oncc"=0), an active PLL2 is locked to the "dirty" external clock "cd" provided by the preceding ASIC in parallel with the input data and generates a "clean" reference clock "cc" for PLL1. The "clean" system clock "cr16" is not needed since PLL2 provides "clock cleaning" functionality.

In the counter clocking mode ("offpll2"=0 & "oncc"=1), PLL2 is used to ensure a robust interface between the driving ASIC and ASNT1016. PLL1 is locked to the "clean" system clock "cr16", while PLL2 is locked to "C16", which is generated by PLL1 and /16. The low speed output clock from PLL2 "cco" controls the output stage of the preceding ASIC and initiates the transmission of its parallel data and respective clock "cd" across the parallel bus to the inputs of ASNT1016.



The serialized words are transmitted as 2-level signals “qcml” by a differential CML output buffer (Data OB). A full-rate clock “cho” is transmitted by a similar CML buffer (HS COB) in parallel with the high-speed data. The clock and data outputs are well phase matched to each other resulting in very little relative skew over the operating temperature range of the device. HS COB may be disabled to save power by means of the 2-state CMOS “offcho” signal. Both output stages are back terminated with on-chip 50Ω resistors.

ASNT1016 also provides a differential low speed output clock derived from PLL1 through a LVDS clock output buffer (LVDS COB). This LVDS output signal “clo” may be configured for either “C16” or full rate clock divided-by-64 “C64” operation through pin “offc64”.

Both PLL1 and PLL2 generate loss of lock signal alarms “lol1n” and “lol2n”. Off chip capacitors are required for both PLLs and are connected through pins “ftr1p/n” and “ftr2p/n”.

The serializer uses a single +3.3V power supply and is characterized for operation from -25°C to 125°C of junction temperature.

LS DIBx16

The Low-Speed Data Input Buffer (LS DIBx16) consists of 16 proprietary universal input buffers (UIBs). UIB is designed to accept differential signals with amplitudes higher than 60mV peak-to-peak (p-p), DC common mode voltage variation between the negative (vee) and positive (vcc) supply voltages, and AC common mode noise with a frequency up to 5MHz and voltage levels ranging from 0 to 2.4V . It can also receive single-ended signals with amplitudes of more than 60mV p-p and threshold voltages between vee and vcc. By default, the input termination impedance is set to 100Ω differential to support the LVDS standard. Correct impedance for the CML and ECL standards (50Ω single ended to vcc) is set by applying logic “0” to “offecl”. Vcc should be applied to “vecl” for CML operation while +2V is needed for ECL input signaling.

LS CIB

The Low-Speed Clock Input Buffer (LS CIB) is a UIB that can run at a frequency up to 800MHz . This block is used for both low speed clock inputs “cd” and “cr16” inputs and is also affected by the “offecl” and “vecl” control signals.

PLL1

The Main Phase Locked Loop (PLL1) contains a phase frequency detector, charge pump, an on-chip integrator with an additional off-chip filtering capacitor of 1nF connected between the pins “ftr1p” and “ftr1n”, two selectable LC-tank VCOs centered at 11.8GHz and 11.0GHz , and a selectable HS clock input buffer with a SE 50Ω input termination.

The main function of PLL1 is to synthesize full rate clock “C” by aligning the phase and frequency of “C16” of the activated VCO to the low-speed reference clock signal that is either applied externally “cr16” or generated internally by PLL2 “cc”.



A logic “0” output CMOS loss-of-lock “lol1n” alarm signal is generated by PLL1 if its two input clock signals are not matching in phase and/or frequency.

Selection of the different VCOs of PLL1 is achieved by utilizing the CMOS control pin “off12g”. A logic “1” chooses the 11.0GHz VCO while a logic “0” selects the 11.8GHz VCO (default state). The unused VCO is turned completely off in order to save power.

The clock multiplication function of PLL1 can be disabled by a CMOS logic “1” level at the control pin “offpll1”. In this case an external HS clock must be applied to “ce” inputs and the chip operates in the digital mode.

PLL2

The Secondary Phase Locked Loop (PLL2) is used for input reference clock “cleaning” in the forward-clocking mode or for output reference clock generation in the counter-clocking mode. It contains a phase frequency detector, charge pump, an on-chip integrator with an additional off-chip filtering capacitor of 47nF connected between the pins “ftr2p” and “ftr2n”, and a ring VCO.

The operational modes of PLL2 are controlled by the external CMOS signals “oncc” and “offpll2”. The default state for both signals is logic “1”, which enables the counter-clocking mode for PLL1, but disables PLL2.

A logic “0” output CMOS loss-of-lock “lol2n” alarm signal is generated by PLL2 if its two input clock signals are not matching in phase and/or frequency.

/16

The Divider-by-16 (/16) includes 4 divide-by-2 circuits connected in series. High-speed clock “C” is fed into the first divide-by-2 circuit that generates “C2”. “C2” is routed internally to the next divide-by-two circuit and outside of the block to MUX16:1. Other divided down clock signals are formed and routed to MUX16:1 in similar fashion. “C16” (“offc64”=1, default) or “C64” (“offc64”=0) is passed on to a LVDS COB and becomes the output low speed clock signal “clo”.

MUX16:1

The 16 to 1 Multiplexer (MUX16:1) utilizes a tree type architecture that latches the incoming data on the negative edge of the “C16” clock signal that is supplied by /16. The 16-bit wide data word is subsequently multiplexed and delivered to Data OB as a serial data stream running at a data rate up to 12.5Gbps. The latency of this circuit block is equal to roughly one period of the low-speed input clock. When “bitorder”=0 (default), “d00” is the MSB and when “bitorder”=1, “d15” is designated the MSB.

Data OB

The Data Output Buffer (Data OB) receives high-speed serial data from MUX16:1 and converts it into the CML output signal “qcml” with a single ended swing of 600mV. The buffer requires 50Ohm external termination resistors connected between “vcc” and each output to match its internal 50Ohm resistors and can operate at a data rate up to 12.5Gbps.

HS COB

The High Speed Clock Output Buffer (HS COB) utilizes the same termination scheme as Data OB and can operate at a frequency up to 12.5GHz while producing a single-ended CML output swing of 600mV. The buffer can be enabled or disabled by the external 2-state control signal “offcho”. The logic “0” state provides a full-rate clock output signal while the logic “1” state disables the buffer completely to save power.

LVDS COB x2

The dual LVDS Clock Output Buffer (LVDS COB x2) receives “cl” and “cc” signals and converts them into the LVDS output signals “clo” and “cco”. Each proprietary low-power LVDS output buffer utilizes a special architecture that ensures operation at frequencies up to 2GHz with a low power consumption level of 30mW. The buffer satisfies all the requirements of the IEEE Std. 1596.3-1996 and ANSI/TIA/EIA-644-1995.

Output Timing

Phase relation between the output data “qcm1” and full rate output clock “cho” is specified in Table 1 and illustrated by Fig. 2.

Table 1. Output Data-to-Clock Phase Difference

Junction temperature, °C	τ , ps	
	Min.	Max.
-25	77	80
50	82	86
125	87	91

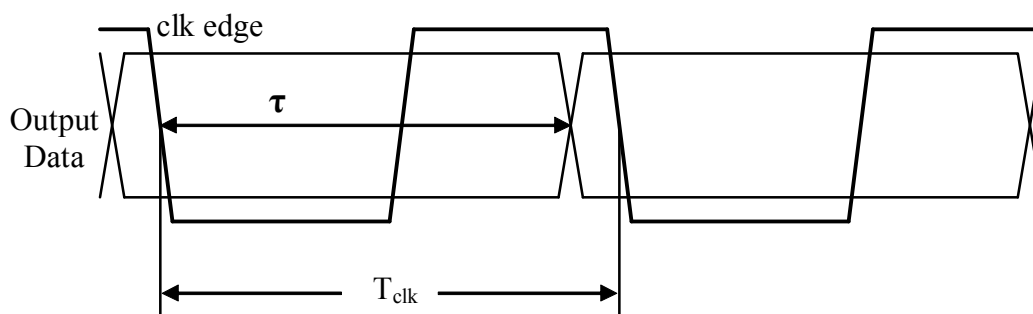

Fig. 2. Output Timing Diagram



TERMINAL FUNCTIONS

The description of the package balls is presented in the table below.

TERMINAL BALL			DESCRIPTION
Name	Code	Type	
High-Speed I/Os			
chop	M11	Output	CML differential clock outputs. Require external SE 50 Ω termination to "vcc". Can be disabled by "offcho".
chon	L12		
qcmlp	H12	Output	CML differential data outputs. Require external SE 50 Ω termination to "vcc".
qcmln	E12		
cep	L6	Input	CML differential clock inputs with on-chip SE 50 Ω termination to "vcc". Used in digital mode of operation as an alternative for the internal clock generated by PLL1.
cen	M6		
Controls			
lol1n	E3	LS Out,	PLL1 lock indicator (high: locked; low: no lock).
lol2n	D3	CMOS	PLL2 lock indicator (high: locked; low: no lock).
ftr1p	K8	I/O	PLL1 external filter connection (1nF capacitor differential).
ftr1n	K9		
ftr2p	F3	I/O	PLL2 external filter connection (47nF capacitor differential).
ftr2n	G3		
offpll1	J10	LS In., CMOS	PLL1 activation (default: low, PLL1 is enabled; active: high, PLL1 is disabled, digital mode of operation).
offc64	K5	LS In., CMOS	Division ratio clock selection (active: low, division by 64; default: high, division by 16).
offpll2	J4	LS In., CMOS	PLL2 activation (active: low, PLL2 is enabled; default: high, PLL2 is disabled).
offcho	K3	LS In., CMOS	HS COB control (active: high, buffer is disabled; default: low, full-rate output clock).
offl2g	K10	LS In., CMOS	VCO frequency selection (active: high, 11.0GHz; default: low, 11.8GHz).
oncc	K6	LS In., CMOS	Counter clocking control (active: low, forward clocking mode; default: high, counter-clocking mode).
bitorder	C4	LS In., CMOS	Input bit order selection (active: high, d15 is serialized first; default: low, d00 is serialized first).
Low-Speed I/Os			
cr16p	A11	Input	Differential reference clock inputs with internal termination selectable through "offec1" and "vecl".
cr16n	B12		
cdp	A6	Input	Differential inputs for clock aligned with data. Internal termination is selectable through "offec1" and "vecl".
cdn	B6		
clop	M8	Output	LVDS clock outputs. Can transmit "C16" or "C64" divided clocks from PLL1 as defined by "offc64".
clon	M9		
ccop	A9	Output	LVDS clock outputs from PLL2.



ccon	A8		
d00p	A5	Input	Differential data inputs with internal termination selectable through "offecl" and "vecl". Default is set to LVDS.
d00n	B5		
d01p	A4		
d01n	B4		
d02p	A3		
d02n	B3		
d03p	A2		
d03n	B2		
d04p	C2		
d04n	C1		
d05p	D2		
d05n	D1		
d06p	E2		
d06n	E1		
d07p	F2		
d07n	F1		
d08p	G1		
d08n	G2		
d09p	H1		
d09n	H2		
d10p	J1		
d10n	J2		
d11p	K1		
d11n	K2		
d12p	L2		
d12n	M2		
d13p	L3		
d13n	M3		
d14p	L4		
d14n	M4		
d15p	L5		
d15n	M5		

Supply and Termination Voltages

Name	Description	Ball Code
vcc	Positive power supply. (+3.3V)	B1, C5, C6, C7, C9, E10, H10, K4, L1
vee	Negative power supply. (GND or 0V)	A1, A7, A10, A12, B7-B11, C8, C10-C12, D5-D9, D11, D12, E4-E9, E11, F4-F12, G4-G9, G11, G12, H4-H9, H11, J3, J5-J9, J11, J12, K7, K11, K12, L7- L11, M1, M7, M10, M12
nc	Unconnected pin.	C3 (removed ball), D4, D10, G10, H3



ELECTRICAL CHARACTERISTICS

PARAMETER	MIN	TYP	MAX	UNIT	COMMENTS
<u>General Parameters</u>					
V _{CC}	+3.14	+3.3	+3.47	V	±5%
V _{EE}		0.0		V	
V _{ECL}		+2.0		V	
Power consumption		660		mW	
Junction temperature	-25	50	125	°C	
<u>LS Input Data (d00-d15)</u>					
Data Rate	612.5		780	Mbps	
Swing (Diff or SE)	0.06		0.8	V	Peak-to-peak
CM Voltage Level	V _{EE}		V _{CC}	V	
<u>LS Input Reference Clock (cr16, cd)</u>					
Frequency	612.5		780	MHz	
Swing (Diff or SE)	0.06		0.8	V	Peak-to-peak
CM Voltage Level	V _{EE}		V _{CC}	V	
Duty Cycle	40%	50%	60%		
<u>HS Output Data (qcml)</u>					
Data Rate	9.8		12.5	Gbps	
Logic "1" level		V _{CC}		V	
Logic "0" level		V _{CC} -0.6		V	
Jitter		12		ps	Peak-to-peak at 12.5Gb/s
<u>HS Output Clock (cho)</u>					
Frequency	9.8		12.5	GHz	
Logic "1" level		V _{CC}		V	
Logic "0" level		V _{CC} -0.6		V	
Jitter		6		ps	Peak-to-peak at 12.5Gb/s
Duty Cycle		50%			
<u>LS Output Clock (clo, cco)</u>					
Frequency	612.5		780	MHz	
Interface		LVDS			Meets the IEEE Std.
<u>CMOS Control Inputs/Outputs</u>					
Logic "1" level	V _{CC} -0.4			V	
Logic "0" level			V _{EE} +0.4	V	

PACKAGE INFORMATION

The chip is packaged in ADSANTEC's custom 144-pin BGA package. The package's mechanical information is available on the company's [website](#).