

DATASHEET

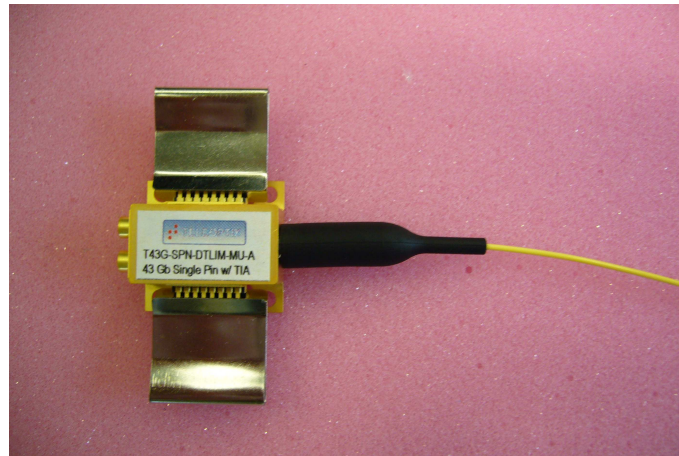

Module information:

Description: The photo-receiver module integrates a photodiode with a Differential Transimpedance Amplifier (*) suitable for 43Gb/s optical transmissions. Thanks to the optical characteristics of the UTC photodiode associated with a high performances limiting amplifier exhibiting a typical differential output swing of 700 mVpp, this photo-receiver is well adapted to OC-768/STM-256 optical transmissions. The module is in a 16 pin package format with GPPO electrical for the HF output and LC/PC connectors for the optical input.

Main Features:

- Up to +3dBm optical input power
- Photodiode is integrated with a limiting or linear Differential transimpedance amplifier
- Differential RF output, AC-coupled
- Butterfly package with GPPO™ connectors or CPW feedthrough
- Low polarisation dependent loss (typ. : 0.2 dB)
- 700 mV differential output swing
- Operating case temperature: 0° ...70°C
- A linear differential transimpedance amplifier is available upon request

Applications :

- 43 Gb/s optical transmissions (OC-768/STM-256)
- WDM (NRZ or PSBT formats) and black/white optical systems

Enclosed data :

1. Block Diagram
2. Absolute Maximum Ratings
3. Typical Operating Conditions
4. Main target specifications
5. Connector and Fibre Specification
6. Mechanical Dimensions
7. Pin Allocation
8. Ordering Information

1. Block Diagram

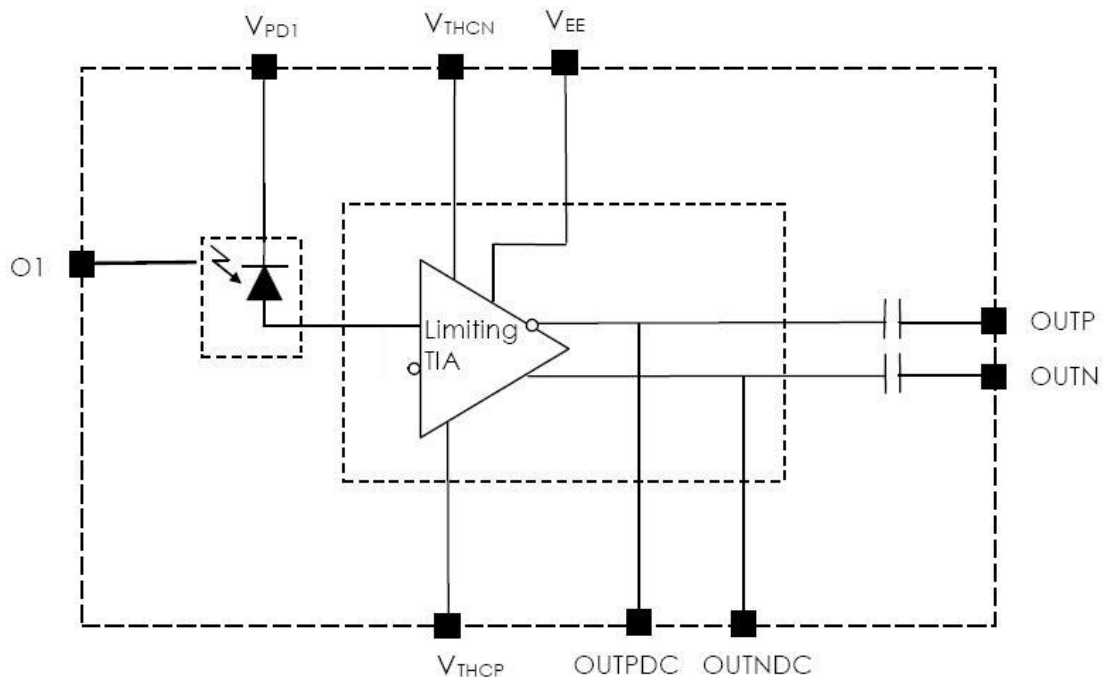

V_{PD1} : Photodiodes power supply voltages

V_{EE} : Amplifier power supply voltage

V_{THCN} , V_{THCP} : Threshold Controls (adjust these values in order to get OUTPUT and OUTNDC balanced)

OUTPUT, OUTNDC : DC output offsets

2. Absolute Maximum Ratings

Parameter	Symbol	Min	Max	Unit
PD bias voltage	V_{PD1}	-0.5	+ 3.5	V
Amplifier power supply voltage	V_{EE}	- 3.5	+0.5	V
Threshold Control Voltage	V_{THCP}, V_{THCN}	- 6.0	+6.0	V
Optical input power	$P_{optIN\ mean}$	-	+ 3	dBm
Operating temperature	T_{OP}	0	+ 70	°C
Storage temperature	T_{ST}	- 40	+ 80	°C

3. Typical Operating Conditions

Parameter	Symbol	Typ.	Unit
Amplifier power supply voltage	V_{EE}	- 3.3	V
Amplifier power supply current	I_{EE}	-130	mA
Threshold Control Voltage	V_{THCP}, V_{THCN}	± 5.0	V
Threshold Control Current	I_{THCP}, I_{THCN}	< 5.0	mA
Amplifier power dissipation	P_{DC}	< 500	mW
PD bias voltage	V_{PD1}	+2.3	V

4. Main Target specifications

N°	Parameter	Symbol	Conditions	Min	Typ.	Max	Unit
1	Wavelength range	λ		1525		1620	nm
2	Optical Input Power ⁽³⁾	P_{optIN_mean}			-2		dBm
3	PD ₁ responsivity	R_{PD1}	$V_{PD1} = + 2.3 V$	0.4	0.55	-	A/W
4	PD dark current	I_{Dark}	$V_{PD1} = + 2.3 V$	-	10	100	nA
5	PDL ₁ polarisation dependent loss	PDL_1	$V_{PD1} = + 2.3 V$	-	0.2	0.5	dB
6	3 dB bandwidth ⁽¹⁾	f_{-3dB}	$V_{PD1} = +2.3V$ $V_{EE} = -3.3 V$	30 (tbc)	35 (tbc)	-	GHz
7	Electrical return loss	S_{22}	DC ~ 20 GHz 20 GHz ~ 45 GHz	-	-10 - 4	-	dB
8	Small signal differential conversion gain ^(2,4)	G_{Conv_diff}	$V_{EE} = -3.3 V$	-	1500	-	V/W
9	Differential output eye amplitude ⁽³⁾	V_{out_diff}	$V_{EE} = -3.3 V$	-	700	-	mV _{pp}
10	OSNR Performance ⁽³⁾	OSNR	BW = 0.1nm BER = 10-9		19		dB
11	OSNR vs Temp ⁽³⁾	$OSNR_{temp}$	from 32 °C Up to 70°C		0.5		dB
12	Power dissipation	P_{DC}	$V_{EE} = -3.3 V$	-	450	500	mW

Notes : (1) : Measurements performed in single-ended operation with 0 dBm optical input power.

(2) : $G_{Conv_diff} = Eye_amp(differential) / P_{opt_INpp}(differential)$.

$P_{optIN_mean} = -10dBm$.

Evaluated from NRZ eye diagram measurements at 43 Gbit/s.

(3) : Evaluated from measurements in 43 Gbit/s DPSK system.

(4) : Differential output voltage.

7. Pin Allocation

Pin	Name	Pin	Name
1	No internal connection	16	VPD1
2	GND	15	GND
3	THCN	14	GND
4	THCP	13	VEE
5	GND	12	No internal connection
6	No internal connection	11	No internal connection
7	OUT P DC	10	No internal connection
8	OUT N DC	9	No internal connection

8. Ordering Information:

For orders or more information, please contact our sales office:

Mi.Tel-Teleoptix srl

Via Guido Rossa, 22

20040 Cornate D'Adda (MI)

ITALY

Tel.: +39 039 6101940

Fax.: +39 039 6101900

www.teleoptix.com

info@teleoptix.com