

DFF-DG-30

30 Gbps D-type Flip-Flop Module



Features

- Data transmission up to 30 Gbps
- 3.3 V to 8 V single voltage power supply
- Low jitter
- Low rise / fall time
- Single ended and differential output

Applications

- Data retiming
- 28 Gbps DPSK
- 2×28 Gbps (D)QPSK
- Research & Development

Options

- Alternative RF output connectors

The DFF-DG-30 is a D-type Flip Flop (DFF) module which is primarily intended for retiming of high data rate signals. The DFF-DG-30 supports data transmission rates up to 30 Gbps and clock frequencies as high as 30 GHz.

The DFF-DG-30 retimes and reshapes single ended input data streams into differential output data streams.

It is also useful when associated with other logical circuits for application such as : NRZ/RZ conversion, DPSK and DQPSK differential encoding, phase detection in PLL loops or memories.

Performance Highlights

Parameter	Min	Typ	Max	Unit
Data rate	2	-	30	Gbps
Data output voltage (single-ended)	-	390	-	mV
SNR	-	15	-	-
CPM	-	200	-	Degree
Rise / Fall Times	-	13 / 13	-	ps

Measurements for $V_{bias} = 5\text{ V}$, $I_{bias} = 136\text{ mA}$

30 Gbps Output Response

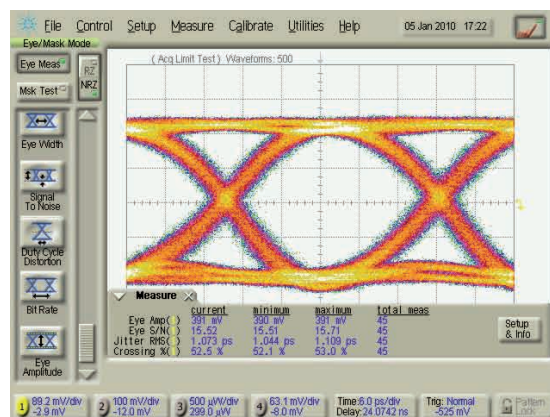

DFF

DFF-DG-30

30 Gbps D-type Flip-Flop Module



DFF

DC Electrical Characteristics

Parameter	Symbol	Condition	Min	Typ	Max	Unit
Supply voltage	V_{bias}		3.3	5	8	V
Current consumption	I_{bias}	$V_{bias} = 5\text{ V}$	-	0.135	-	A

Electrical Characteristics Conditions: $V_{bias} = 5\text{ V}$, $T_{amb} = 25\text{ °C}$, 50 Ω system

Parameter	Symbol	Condition	Min	Typ	Max	Unit
Data rate	D_{in}	NRZ format @ f_{Clk}	2	-	30	Gbps
Clock frequency	f_{Clk}	-	2	-	30	GHz
Data input voltage	V_{Din}	-	100	300	800	mV _{pp}
Clock input voltage	V_{Clk}	-	100	300	800	dB
Data output voltage	V_{Dout}	Single-ended	370	390	420	mV _{pp}
	$V_{Dout+} - V_{Dout-}$	Differential	740	780	840	
Data input return loss	$S11_{Din}$	$f < 10\text{ GHz}$	-	-	-10	dB
Clock input return loss	$S11_{Clk}$	$f < 10\text{ GHz}$	-	-	-10	dB
Data output return loss	$S22_{Dout}$	$f < 10\text{ GHz}$	-	-	-10	dB
Signal noise ratio	SNR	-	-	15	-	-
Clock phase margin	CPM	@28 Gbps	-	200	-	Degree
Rise time / Fall time	t_r / t_f	20 % - 80 %, 28 Gbps	-	13 / 13	-	ps
Power dissipation	P_{diss}	$V_{bias} = 5\text{ V}$	0.675	-	-	W

Absolute Maximum Ratings

Stresses in excess of the absolute maximum ratings can cause permanent damage to the device. These are absolute stress ratings only. Functional operation of the device is not implied at these or any other conditions in excess of those given in the operational sections of the data sheet. Exposure to absolute maximum ratings for extended periods can adversely affect device reliability.

Parameter	Symbol	Min	Max	Unit
Data input voltage	D_{in}	0	800	mV _{pp}
Clock input voltage	V_{Clk}	0	800	mV _{pp}
Supply voltage	V_{bias}	0	8	V
Power dissipation	P_{diss}	-	0.7	W
Temperature of operation	T_{op}	0	+40	°C
Storage temperature	T_{st}	-20	+70	°C

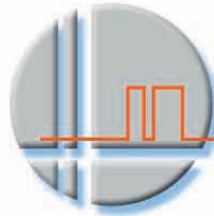

DFF-DG-30 30 Gbps D-type Flip-Flop Module

DFF

Example of Reshaped Eye Diagrams

12.5 Gbps data rate

Conditions: Ratio $\frac{1}{2}$, Pattern $2^{31}-1$

$V_{bias} = 5\text{ V}$, $I_{bias} = 136\text{ mA}$

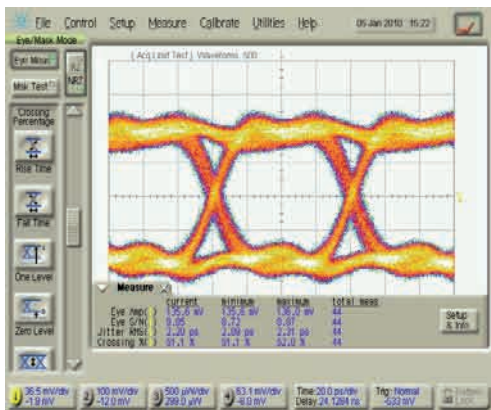

Input signal

Eye amplitude = 0.135 V, Rise time = 15 ps
Jitter RMS = 2.2 ps, SNR = 8.85

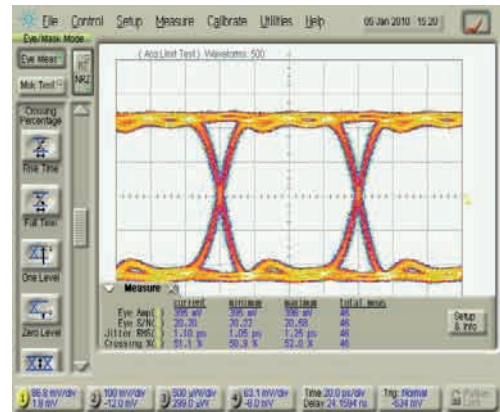

Output reshaped signal

Measured using Agilent 86100B with two 50 GHz
8348A channels module, and without precision time-base module
Eye amplitude = 0.395 V, Rise time = 12.9 ps
Jitter RMS = 1.1 ps, SNR = 20.2

25 Gbps data rate

Conditions: Ratio $\frac{1}{2}$, Pattern $2^{31}-1$

$V_{bias} = 5\text{ V}$, $I_{bias} = 136\text{ mA}$

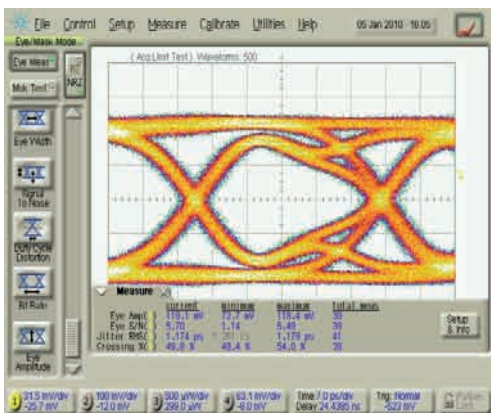

Input signal

Eye amplitude = 0.118 V, Rise time = 13.1 ps
Jitter RMS = 1.17 ps, SNR = 5.7

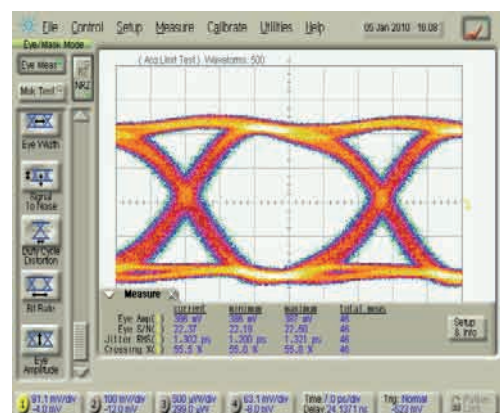

Output reshaped signal

Measured using Agilent 86100B with two 50 GHz
8348A channels module, and without precision time-base module
Eye amplitude = 0.386 V, Rise time = 12.6 ps
Jitter RMS = 1.3 ps, SNR = 22.37

Example of Reshaped Eye Diagrams

28 Gbps data rate

Conditions: Ratio $\frac{1}{2}$, Pattern $2^{31}-1$

$V_{bias} = 5\text{ V}$, $I_{bias} = 136\text{ mA}$

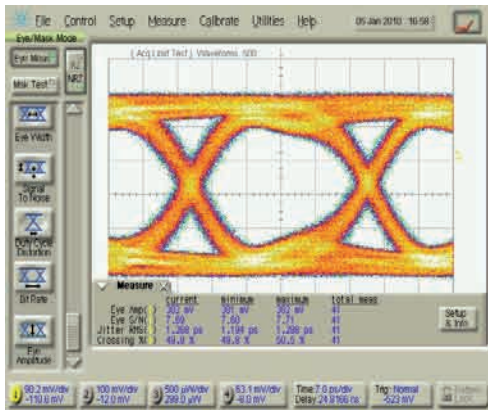

Input signal

Eye amplitude = 0.382 V, Rise time = 11.36 ps
Jitter RMS = 1.27 ps, SNR = 7.69

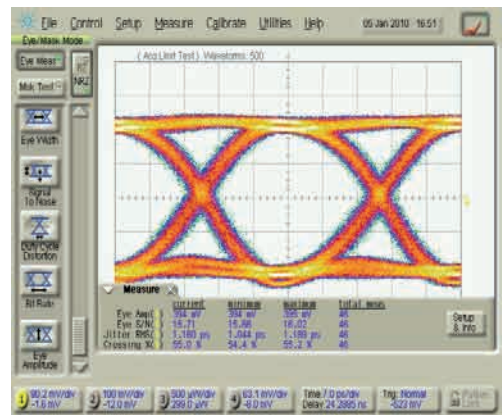

Output reshaped signal

Measured using Agilent 86100B with two 50 GHz 8348A channels module, and without precision time-base module
Eye amplitude = 0.394 V, Rise time = 13.07 ps
Jitter RMS = 1.16 ps, SNR = 15.7

30 Gbps data rate

Conditions: Ratio $\frac{1}{2}$, Pattern $2^{31}-1$

$V_{bias} = 5\text{ V}$, $I_{bias} = 136\text{ mA}$

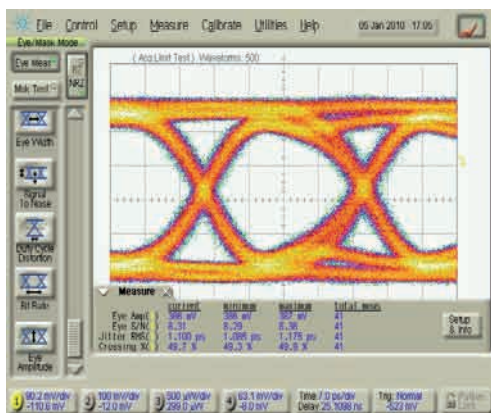

Input signal

Eye amplitude = 0.386 mV, Rise time = 11.36 ps
Jitter RMS = 1.1 ps, SNR = 8.31

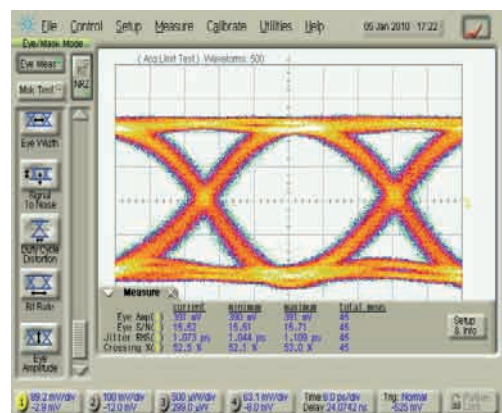

Output reshaped signal

Measured using Agilent 86100B with two 50 GHz 8348A channels module, and without precision time-base module
Eye amplitude = 0.391 V, Rise time = 13.73 ps
Jitter RMS = 1.073 ps, SNR = 15.52

DFF-DG-30
30 Gbps D-type Flip-Flop Module

DFF

Electrical Schematic Diagram

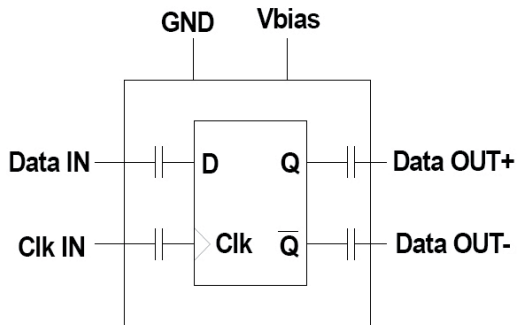

Clock	DATA IN	DATA OUT	DATA OUT previous
Rising edge ↑	0	0	X
Rising edge ↑	1	1	X
No clock or non-rising edge	X	Previous state	X

X : "don't care" condition (signal is irrelevant)

Mechanical diagram and pinout

All measurements in mm

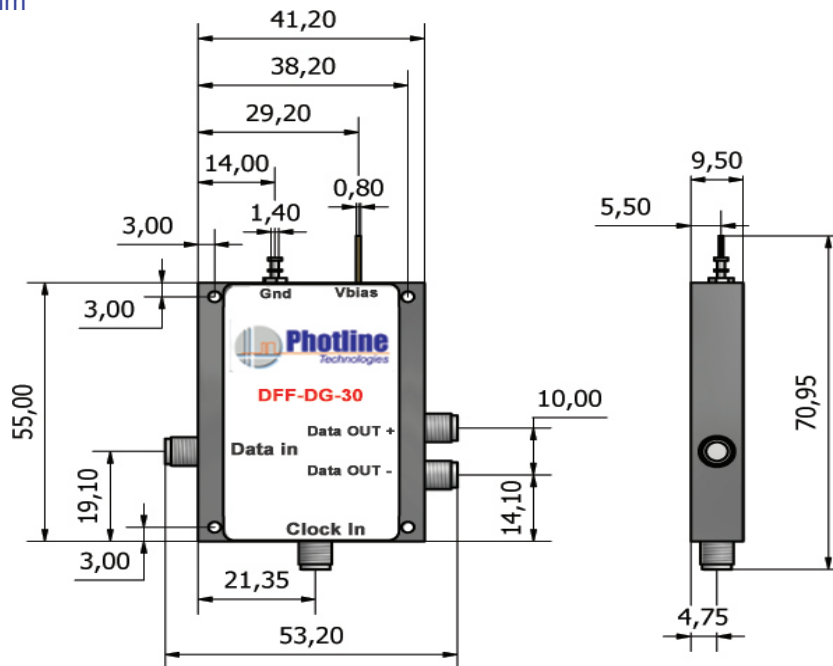

PIN	Function	Operational Notes
Data In	Data RF input	K-connector female
Clock In	Clock RF input	K-connector female
V _{bias}	Power supply voltage	Pin feed through diameter 0.8 mm
Gnd	Ground	Pin feed through diameter 1.4 mm
Data Out -	RF output	K-connector female (male in option)
Data Out +	RF output	K-connector female (male in option)

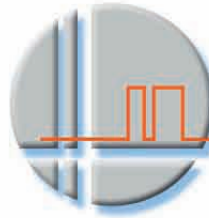

DFF-DG-30 22 Gbps High Output Voltage Driver Module

DFF

Related equipments

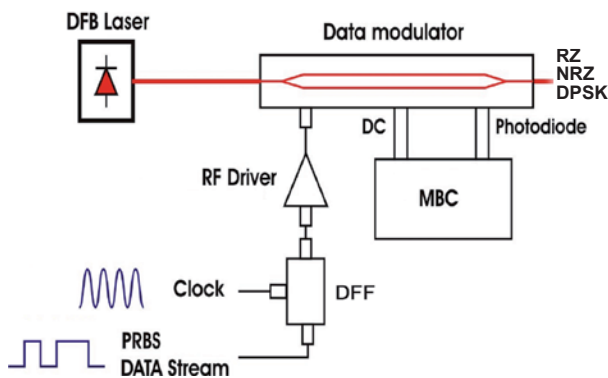

RZ / NRZ / DPSK datastream reshaping

MX-LN series modulators are intended for 10 / 28 / 40 Gbps RZ / NRZ / DPSK modulation formats.

DR-DG amplifiers series are intended to drive MX-LN series modulators for 10 / 28 / 40 Gbps RZ / NRZ / DPSK modulation formats.

MBC-DG-BT is an automatic bias controller designed to lock the operating point of the MX-LN modulators.

ABOUT US

Photline Technologies is a provider of Fiber Optics Modulation Solutions based on the company LiNbO3 modulators and high-speed electronics modules. Photline Technologies offers high speed and high data rate modulation solutions for the telecommunication industry and the defense, aerospace, instruments and sensors markets. The products offered by the company include : comprehensive range of intensity and phase modulators (800 nm, 1060 nm, 1300 nm, 1550 nm), RF drivers and modules, transmitters and modulation units.

Photline Technologies
phone : +33 (0) 381 853 180
fax : +33 (0) 381 811 557
16, rue Auguste Jouchoux
F-25 000 Besançon

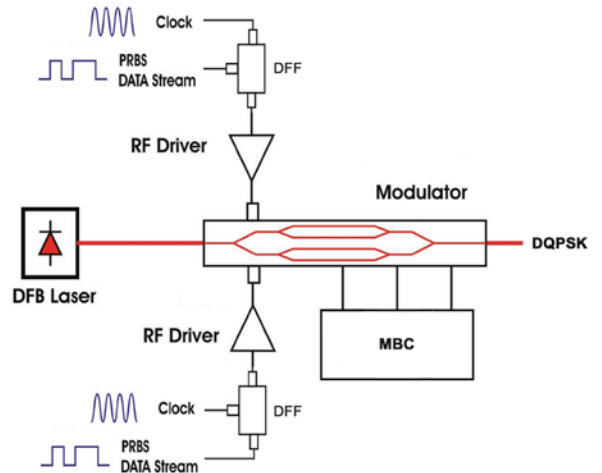

DQPSK datastream reshaping

MXIQ-LN-40 is an ultra low loss IQ modulator for 2 x 22 Gbps DQPSK modulation.

DR-DG-20-HO amplifiers are intended to drive MXIQ-LN-40 modulator with 2 x V_{π} signal for 2 x 22 Gbps DQPSK modulation.

MBC-IQ-BT is an automatic bias controller designed to individually lock the operating point of the MXIQ-LN-40 sub-MZs.

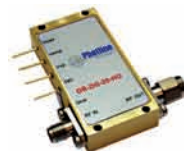

Photline Technologies reserves the right to change, at any time and without notice, the specifications, design, function or form of its products described herein. All statements, specification, technical information related to the products herein are given in good faith and based upon information believed to be reliable and accurate at the moment of printing. However the accuracy and completeness thereof is not guaranteed. No liability is assumed for any inaccuracies and as a result of use of the products. The user must validate all parameters for each application before use and he assumes all risks in connection with the use of the products.