

# Price List

## Plano-concave lenses

### SQ1 (fused silica)

valid from March 2001



The lenses listed below are selected from our comprehensive product range and are all available ex-stock. All lenses feature  $\lambda/10$  surface figure and research grade laser polish for high power laser applications.

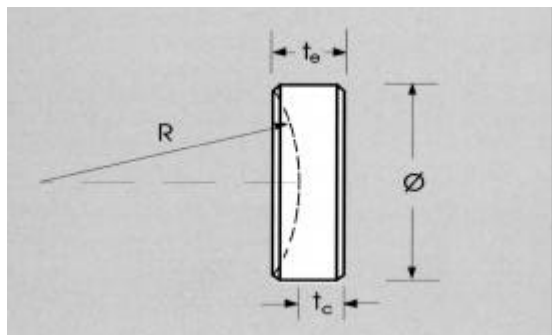

#### Specifications

Material	SQ1
Surface figure	$\lambda/10$ (632 nm) both sides
Surface quality	5/4 x 0.025 both sides
Diameter tolerance	+ 0.00, -0.25 mm
Thickness tolerance	$\pm$ 0.25 mm
Chamfer	0.2 - 0.4 mm
Clear aperture	85% of diameter
Concentricity	$\pm$ 0.2 mm, (4/3')
Focal length tolerance	$\pm$ 1%

Part number

**PLCC**

-

**25.4**

/

**25.8**

**UV**

Product  
code

Diameter  
mm

Radius  
mm

Material  
code

Nominal f (mm)	Diameter Ø (mm)	248 nm f (mm)	308 nm f (mm)	355 nm f (mm)	1064 nm f (mm)	Radius R (mm)	t <sub>c</sub> (mm)	t <sub>e</sub> (mm)	Part number	Price / EURO
-25.0	10.0	-25.4	-26.6	-27.1	-28.7	12.9	2.0	3.0	PLCC-10.0/12.9UV	170,00
-40.0	10.0	-40.5	-42.4	-43.3	-45.8	20.6	2.0	2.6	PLCC-10.0/20.6UV	140,00
-50.0	25.4	-50.7	-53.1	-54.2	-57.4	25.8	2.0	5.3	PLCC-25.4/25.8UV	150,00
-75.0	25.4	-75.9	-79.5	-81.1	-85.8	38.6	2.0	4.1	PLCC-25.4/38.6UV	150,00
-100.0	25.4	-101.3	-106.0	-108.2	-114.5	51.5	2.0	3.6	PLCC-25.4/51.5UV	140,00
-150.0	25.4	-152.0	-159.2	-162.4	-171.9	77.3	2.3	3.4	PLCC-25.4/77.3UV	140,00
-200.0	25.4	-202.5	-212.1	-216.4	-229.1	103.0	2.3	3.1	PLCC-25.4/103.0UV	140,00
-250.0	25.4	-253.3	-265.3	-270.3	-286.5	128.8	2.0	2.6	PLCC-25.4/128.8UV	140,00
-1000.0	25.4	-1012.9	-1060.7	-1082.0	-1145.6	515.1	2.0	2.2	PLCC-25.4/515.1UV	140,00

All items also available with AR coating.

For additional lenses please refer to our Laser Optics catalogue

**All prices net in EURO**

Issue: March 2001, replaces issue from June 1999 / Version 4 / HW / PLCCPLCX.XLS/Plankonkav-Linsen englisch

A minimum order surcharge of 5,- € will be applied to all orders of less than 50,- €.

All prices are subject to change without notice

Delivery: ex works Olching

Prices: packing and insurance excluded

Terms of Payment: 30 days net

Wir akzeptieren / We accept

