

ModBox-VNA-CBand series

CBand, 40 GHz, 65 GHz Modulation Unit

PHOTLINE ModBox



The ModBox-VNA-CBand is a C-Band and wide bandwidth Optical Transmitter designed to extend Vectorial Network Analyzers applications into the optical domain.

When associated with a Vectorial Network Analyzer, they make up a high performance and easy to use test equipment for the characterization of photoreceivers or any high speed optoelectronic device.

The ModBox-VNA-CBand incorporates a 1550 m low low RIN DFB laser source and a modulation stage based on a high bandwidth LiNbO_3 modulator with an automatic bias control circuit.

FEATURES

- Analog modulation up to 40GHz, 65 GHz
- Dither-free bias controller
- Low RIN
- High harmonics suppression

APPLICATIONS

- Transmission system test
- Components characterization
- Receiver frequency test
- R&D laboratories

OPTIONS

- 850 nm, L, O bands operation
- Multi-Channel

Performance Highlights

Parameter	Min	Typ	Max
Operating wavelength	1530 nm	1550 nm	1560 nm
Modulation format	Analog Modulations		
Modulation bandwidth	-	-	40 GHz, 65 GHz
Modulated output power	5 mW	8 mW	-

Functional Block Diagram

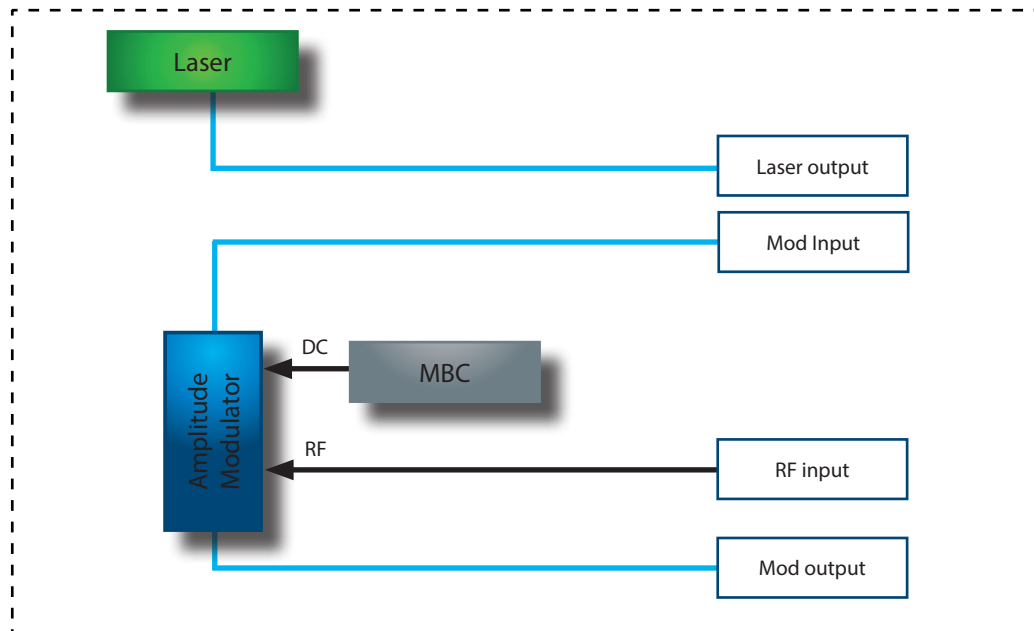

The ModBox-VNA-CBand features:

- A chirp-free X-cut LiNbO₃ (Lithium Niobate) Mach-Zehnder Analog Intensity modulator. It is selected for its high electro-optic bandwidth and flat, low ripple, electrooptic response curve.
- A modulator bias controller. The internal LiNbO₃ modulator is a X-cut device with very low drift. However an automatic bias control circuit is provided to lock the operating point of the modulator at the quadrature point whatever the environmental conditions. The bias control circuit is dither free and therefore does not add any spurious content to the small signal modulation generated by the VNA. It is pre-set for operation in quadrature, in the linear portion of the modulator transfer curve. The system can operate over a large power dynamic range thanks to its software controllable gain parameters).
- An 1550 nm low RIN laser. For ease of use, an external patch cord is delivered to connect the laser output to the modulator input optical port. Wavelength and power are tunable through the front panel controls or the ModBox software interface.

The ModBox-VNA-CBand is controlled from the front panel thanks to the Smart interface with a simple rotary knob and keypad. The Smart manual interface allows for bias control circuit, drivers gain and laser current settings. It comes also with a simple GUI solution, Windows based and implemented through the USB interface of the user PC.

Input Electrical Specifications User supplied, not a ModBox specification

Parameter	Symbol	Condition	Min	Typ	Max	Unit
Input electrical termination	-	AC coupled	Single ended			-
Signal type	-	-	Analog			-
Input voltage ⁽¹⁾	V_{IN}	Amplitude Modulation	0.4	0.6	1	Vpp
Impedance matching	Z_{IN-RF}	-	-	50	-	Ω

(1): The ModBox-VNA-CBand does NOT feature an internal RF amplifier. The VNA characterization is usually performed in a "small signal mode", therefore a RF amplifier is not necessary. Omitting the amplifier allows to obtain a smoother and flatter transfer function.

DFB Laser Specifications

Parameter	Symbol	Condition	Min	Typ	Max	Unit
Wavelength	λ	Other ITU-Channel on request	1550.12 nm- ITU CH 34			-
Laser type	-	-	DFB			-
Spectrum linewidth	$\Delta\lambda$	FWHM	-	1	-	MHz
Side mode suppression ratio	SMSR	-	40	55	-	dB
Wavelength laser tuning range	-	GUI	-	0.8	1	nm
RIN	RIN	-	-	-	-145	dB/Hz

Output Specifications

Parameter	Symbol	Condition	Min	Typ	Max	Unit
Modulation bandwidth	-	ModBox-VNA-CBand-40GHz	-	35	40	GHz
	-	ModBox-VNA-CBand-65GHz	-	60	65	GHz
Modulated output power	-	With internal DFB laser	5	8	-	mW
Optical return loss	ORL	-	-45	-50	-	dB
Electrical return loss	ERL	-	-	-12	-10	dB
Static extinction ratio	ER	-	20	25	-	dB

Optional C-Band Tunable Laser Specifications

Parameter	Symbol	Condition	Min	Typ	Max	Unit
Optical wavelength range	λ_{C-band}	Smart & GUI	1527.60	-	1565.50	nm
Spectrum linewidth	$\Delta\lambda$	FWHM @-3 dB, instantaneous	-	-	100	kHz
Optical output power	P_{cw}	Smart & GUI	5	-	35	mW
Side Mode Suppression Ratio	SMSR	-	40	55	-	dB
RIN	RIN	For 7 dBm (13 dBm) output power	-	-	-140 (-145)	dB/Hz

Absolute Maximum Ratings

Parameter	Symbol	Min	Max	Unit
RF input power	EP_{in}	-	28	dBm
Optical input power	OP_{in}	-	20	dBm

Front Panel

Parameter	
Power	Powers the system and lits green when the switch is set on
LCD	Displays ModBox current status and allows the user to edit parameter in the ModBox menus
Keypad	Allows one to browse through the smart interface menus and edit the system's parameters
System rotary knob	Allows browsing and editing through the ModBox menus
Mod In / Mod Out	Amplitude modulation input and output optical ports
RF input	Single 1.85 mm RF connector
Laser Out	Laser output optical port



Two channels ModBox - VNA example - Front

Ordering information

ModBox-VNA-CBand-XXGHz-YY

VNA = Optical Vectorial Network Analyser extension
 CBand = Embeds laser, 1550 nm by default
 XX = Analog Modulation bandwidth: 40GHz up to 40 GHz 65 GHz up to 65 GHz
 YY = Output connectors, FA : FC/APC - FC : FC/UPC - SC : SC/UPC

Opt-TunC-YY

Tunable laser option:
 YY = Input / Output connectors - FA : FC/APC - FC : FC/UPC - SC : SC/UPC

About us

iXBlue Photonics includes iXBlue iXfiber brand that produces specialty optical fibers and Bragg gratings based fiber optics components and iXBlue Photline brand that provides optical modulation solutions based on the company lithium niobate (LiNbO₃) modulators and RF electronic modules.

iXBlue Photonics serves a wide range of industries: sensing and instruments, defense, telecommunications, space and fiber lasers as well as research laboratories all over the world.

3, rue Sophie Germain
 25 000 Besançon - FRANCE
 Tel. : +33 (0) 381 853 180 - Fax : + 33 (0) 381 811 557

Ixblue reserves the right to change, at any time and without notice, the specifications, design, function or form of its products described herein. All statements, specification, technical information related to the products herein are given in good faith and based upon information believed to be reliable and accurate at the moment of printing. However the accuracy and completeness thereof is not guaranteed. No liability is assumed for any inaccuracies and as a result of use of the products. The user must validate all parameters for each application before use and he assumes all risks in connection with the use of the products