



700-900nm OPTICAL ISOLATORS

www.isowave.com
64 Harding Avenue
Dover NJ 07801
Phone 973-328-7000
Fax 973-328-7036
sales@isowave.com

DESCRIPTION

ISOWAVE offers a wide variety of isolators for the 700-900nm wavelength band (1).
Features to choose from include 2mm, 3mm, 4mm and 5mm clear apertures, fixed or tunable polarizers, broad band isolation and three power level options*. Single and Semi-Double (SD) and True Double (U) stage versions provide different isolation level options. A Faraday rotator (FR) with no polarizers is also available.

*Low - Absorptive glass plate

*Medium - Glan Taylor Polarizer

*High - Glan Taylor Polarizer with dual escape ports

FEATURES

- Wide Tuning Range
- Removable Mounting Collar
 - High Isolation
 - Low Insertion Loss
- Compact Double Stage

MODEL NUMBER	Clear Aperture (2) mm	Tunable Yes/No	Broad-band Yes/No	Isolation Minimum / Typical dB	Ins Loss (3) Typical / Maximum dB	Transmission Minimum / Typical (3) %	Power Handling W/cm2	Diameter inch / mm	Length inch/mm
I-80-2-FR	2	N	N	30 / 35	0.2	95	300	1.0 / 25.4	2.40 / 61
I-80-2L	2	N	N	38 / 40	0.5 / 0.8	83 / 89	50	1.0 / 25.4	2.40 / 61
I-80-2M	2	N	N	38 / 40	0.4 / 0.7	85 / 91	100	1.0 / 25.4	3.54 / 90
I-80-2H	2	N	N	38 / 40	0.4 / 0.7	85 / 91	250	1.0 / 25.4	4.13 / 105
I-7090C-2L	2	N	Y	35 / 38	0.5 / 0.8	83 / 89	50	1.0 / 25.4	2.40 / 61
I-7090C-2M	2	N	Y	38 / 40	0.5 / 0.75	84 / 89	100	1.0 / 25.4	3.54 / 90
I-7090C-2H	2	N	Y	38 / 40	0.5 / 0.75	84 / 89	250	1.0 / 25.4	4.13 / 105
I-80U-2	2	N	N	60 / 63	0.9 / 1.4	72 / 81	50	1.0 / 25.4	3.31 / 84
I-80-3L	3	N	N	38 / 40	0.5 / 0.8	83 / 89	50	1.0 / 25.4	2.40 / 61
I-80-3-FR	3	N	N	30 / 35	0.2	95	300	1.0 / 25.4	2.40 / 61
I-80-3M	3	N	N	38 / 40	0.4 / 0.7	85 / 91	100	1.0 / 25.4	3.54 / 90
I-80-3H	3	N	N	38 / 40	0.4 / 0.7	85 / 91	250	1.0 / 25.4	4.13 / 105
I-80B-4	4	Y	N	30 / 35	3 to 6	25 to 50	10	0.75 / 19	1.48 / 37.6
I-80-4-FR	4	N	N	30 / 35	0.2	95	300	1.375 / 34.9	3.07 / 78
I-80T-4L	4	Y	N	38 / 40	0.5 / 0.8	83 / 89	50	1.375 / 34.9	3.03 / 77
I-80T-4M	4	Y	N	38 / 40	0.4 / 0.7	85 / 91	100	1.375 / 34.9	4.17 / 106
I-80T-4H	4	Y	N	38 / 40	0.4 / 0.7	85 / 91	250	1.375 / 34.9	5.01 / 127
I-80U-4	4	N	N	60 / 63	0.9 / 1.4	72 / 81	50	1.375 / 34.9	3.9 / 99
I-80-5-FR	5	N	N	30 / 35	0.2	95	300	1.375 / 34.9	3.07 / 78
I-80T-5L	5	Y	N	38 / 40	0.5 / 0.8	83 / 89	50	1.375 / 34.9	4.17 / 106
I-80T-5M	5	Y	N	38 / 40	0.4 / 0.7	85 / 91	100	1.375 / 34.9	4.17 / 106
I-80T-5H	5	Y	N	38 / 40	0.4 / 0.7	85 / 91	250	1.375 / 34.9	5.01 / 127
I-7090C-L	5	Y	Y	38 / 40	0.5 / 0.8	83 / 89	50	1.375 / 34.9	4.17 / 106
I-7090C-M	5	Y	Y	38 / 40	0.5 / 0.75	84 / 89	100	1.375 / 34.9	4.17 / 106
I-7090C-H	5	Y	Y	38 / 40	0.5 / 0.75	84 / 89	250	1.375 / 34.9	5.01 / 127
I-80-SD-L	5	Y	N	55 / 60	1.0 / 1.5	70 / 79	50	1.375 / 34.9	4.69 / 119
I-80-SD-M	5	Y	N	55 / 60	1.0 / 1.5	70 / 79	100	1.375 / 34.9	4.69 / 119
I-80-SD-H	5	Y	N	55 / 60	1.0 / 1.5	70 / 79	250	1.375 / 34.9	4.97 / 127

Part Number Options

FR = Faraday Rotator
L, M, H = Polarizer Power Level Options: Low, Medium, High
C = Broadband Isolation: 30dB over +/-50nm no tuning required
T = Tunable: Input polarizer may be rotated to maximize isolation
SD = Semi Double: Single center polarizer, two rotator isolator.
UHP = Ultra High Performance: Full double stage isolator

Wavelength Options

* (1) All isolators may be ordered centered anywhere between 700-900nm with 780nm as standard. Isowave will optimize on best effort basis using available lasers, or customer may supply laser for alignment and testing.
* (2) Unless otherwise specified, all 5mm CA isolators are available as 4mm CA with identical mechanical and optical specifications
* (3) All Low Power models will have higher insertion loss below 780nm.

DS7090 R012010

Specifications subject to change without notice

**700-900nm
OPTICAL ISOLATORS**

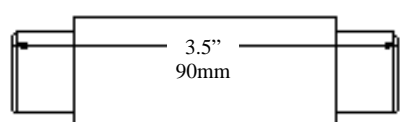
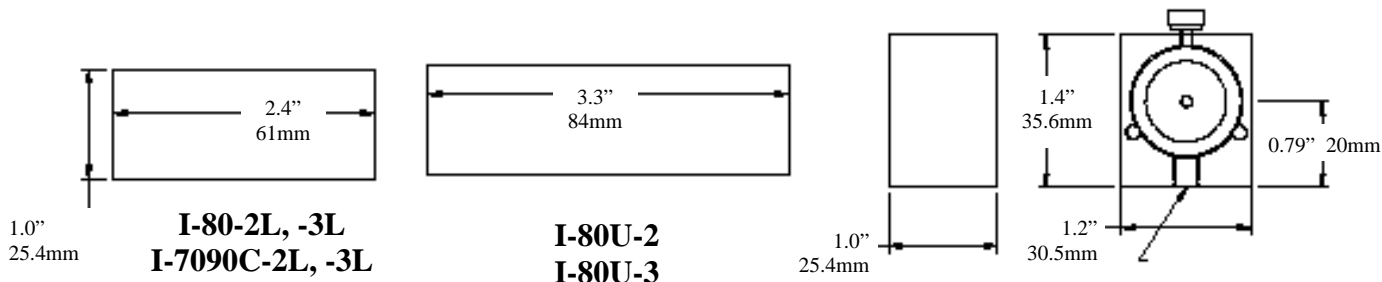

**I-80-2M, -3M
I-7090C-2M, -3M**

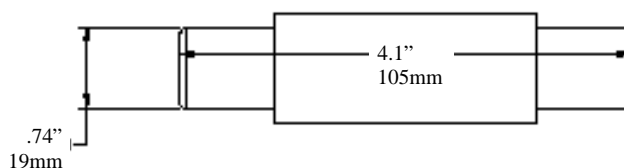

**I-80-2H, -3H
I-7090C-2H, -3H**

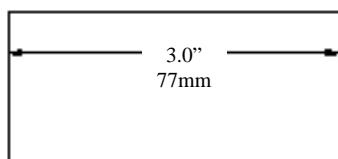

**I-80U-4
750-820nm I-80T-4L**

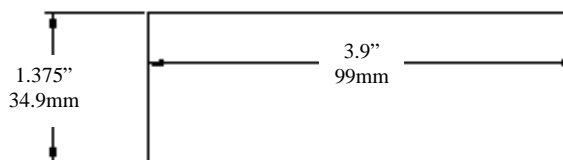

**I-80U-4
830-880nm**

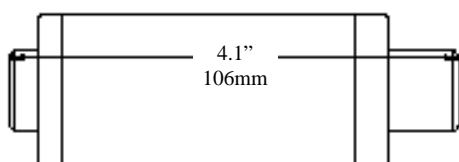

**I-80T-4M
I-80T-5L or -5M
I-7090C-L or -M**

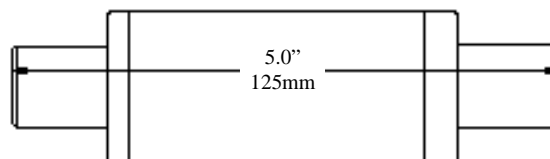

**I-80T-4H
I-80T-5H
I-7090C-H**

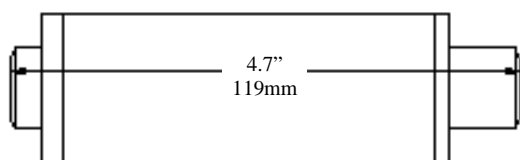

**I-80-SD-L
I-80-SD-M, -4M**

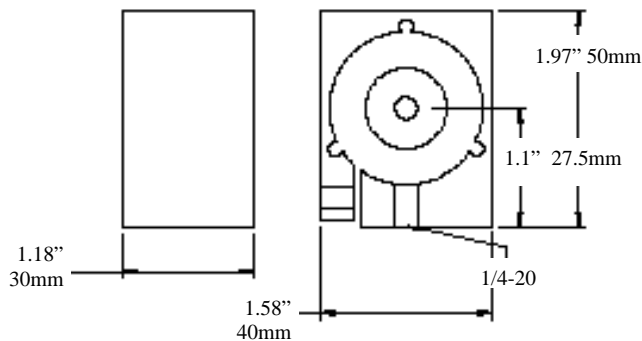

700-900nm Single Stage Isolators

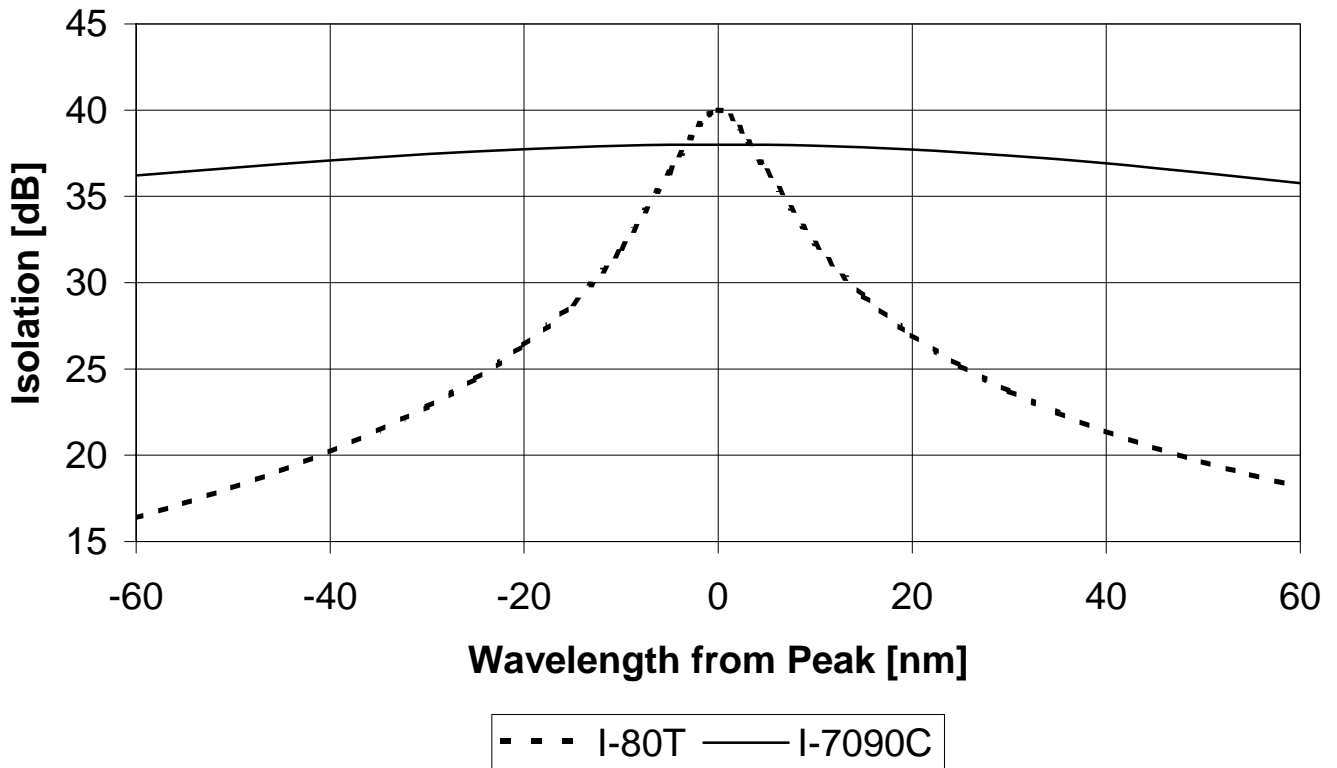

700-900 Semi-Double & Double Stage (UHP) Isolators

