

**CinCam CMOS Nano  
- Technical Data -**

	<b>CMOS-1201-Nano</b>	<b>CMOS-1.001-Nano</b>
	<i>Nano Series</i>	<i>Nano Series</i>
<b>SENSOR DATA</b>		
Format:	1/1.8"	1"
Active area (without cover glass):	6.8mm x 5.4mm	11.3mm x 11.3mm
Number of pixel:	1280 x 1024 (1.3MPixel)	2048 x 2048 (4.2MPixel)
Pixel size:	5.3µm x 5.3µm	5.5µm x 5.5µm
Spectral response (+ UV / NIR / IR Option*):	320nm - 1150nm	320nm - 1150nm
Beam diameter min / max (recommended):	53µm / 4.1mm	55µm / 7.5mm
<b>CAMERA FEATURES</b>		
Mount:	Filter-Mount	Filter-Mount
Bit depth (output):	10Bit	10Bit
Dynamic:	>62dB (1:1250)	>60dB (1:1000)
Frame rate:	up to 30Hz (60Hz)	up to 20Hz (40Hz)
Exposure time:	50µs-1s	50µs-1s
Interface:	USB 3.0	USB 3.0
Shutter:	Global	Global
Mode:	TTL-Signal	TTL-Signal
Trigger:	cw or pulsed	cw or pulsed
<b>SPECIFICATIONS</b>		
Mechanical dimensions (W x H x L):	29mmx29mmx20mm	29mmx29mmx24mm
Weight:	26g	28g
Electrical requirements:	Power supply via USB	Power supply via USB
Storage temperature**:	-10°C...+60°C	-10°C...+60°C
Operating temperature**:	+0°C...+40°C	+0°C...+40°C
Regulations:	CE, RoHS	CE, RoHS

\* UV Option: Sensor Coating (<150nm-1150nm) / Without Microlenses (240nm-1150nm)

NIR Option: Residual Silicon Response (320-1320nm)

IR Option: Sensor Coating (1495nm-1595nm)

\*\* Without condensation

Design and specification of the described product(s) are subject to change without notice.

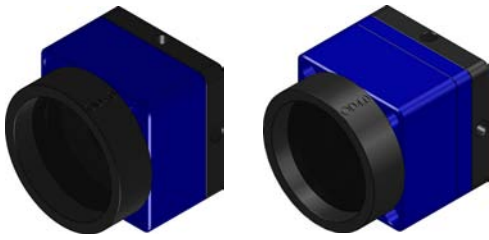

**CinCam CMOS Nano**  
**- Sensor Response -**  
**- Dimensions -**

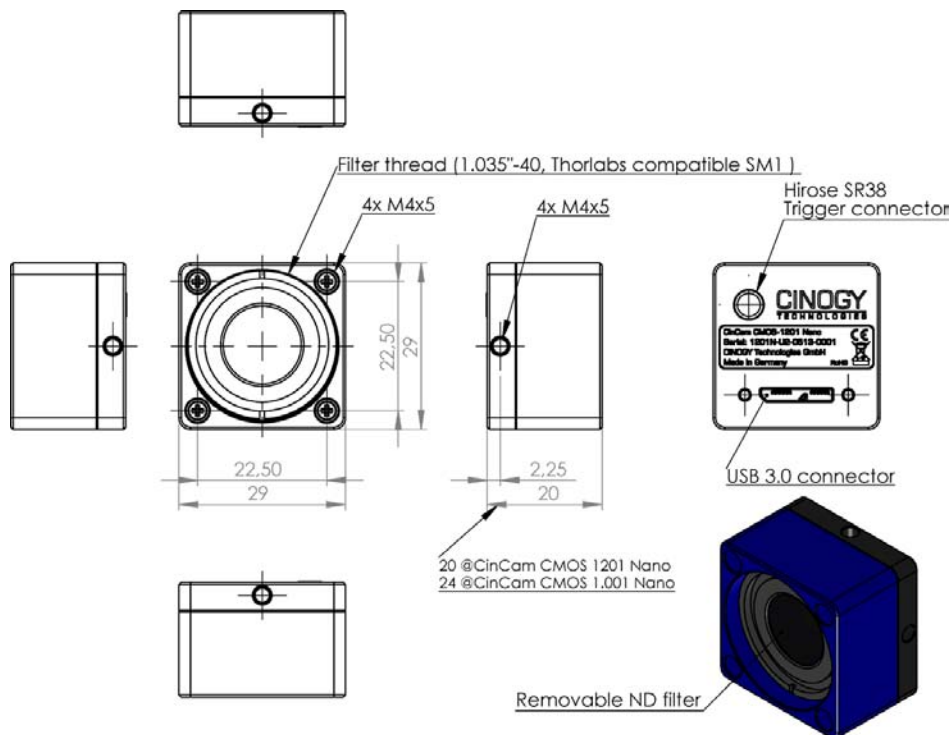
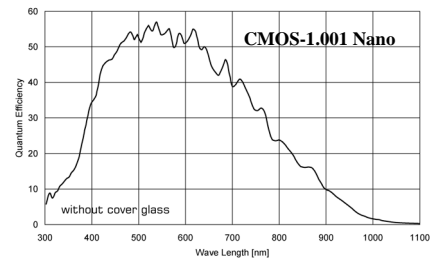
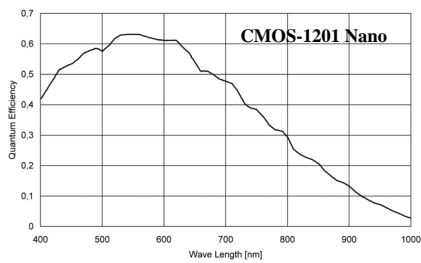

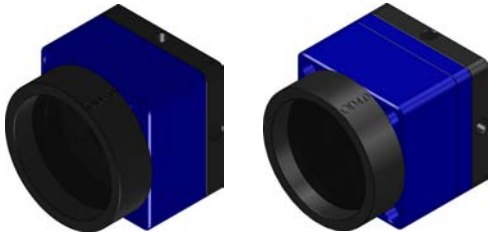

**CinCam CMOS Nano  
- Operational Range -**

**Maximum CW power for saturation limit**

**Maximum PULSE energy for saturation limit  
(single pulse during the exposure time)**

**CinCam CMOS-1201 Nano**

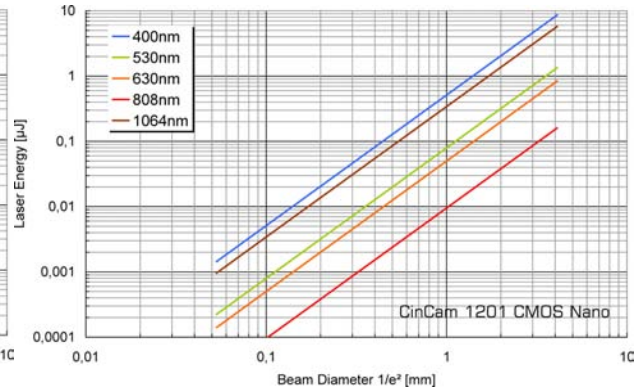
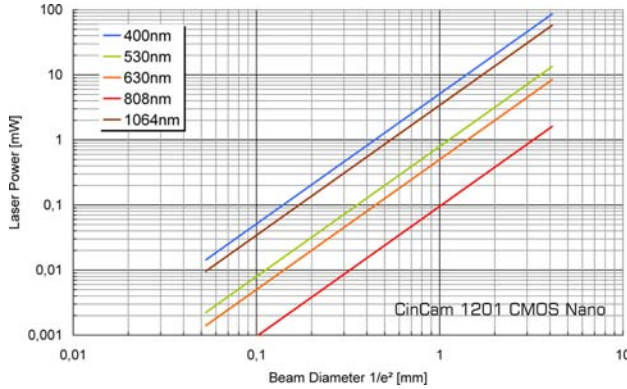

**CinCam CMOS-1.001 Nano**

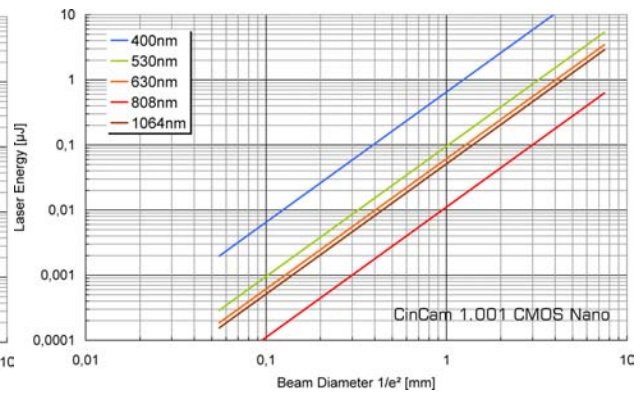
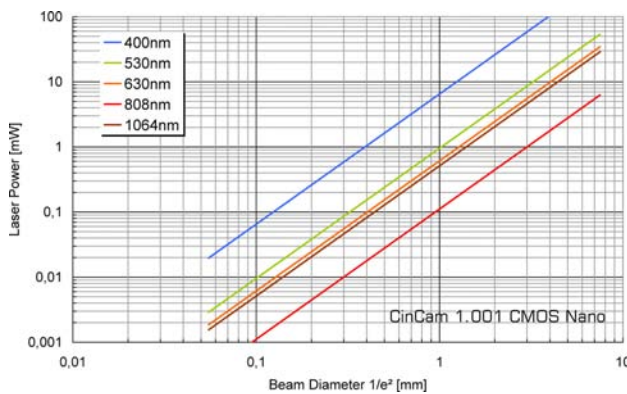

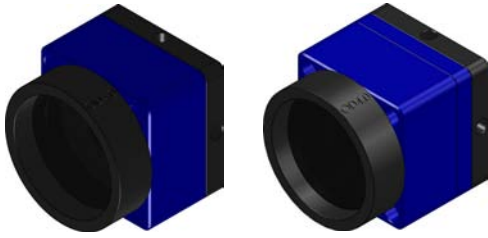

**CinCam CMOS Nano  
- Operational Range -**

**Saturation limit assumes:**

Saturation level:	90%
Built-in ND-Filter:	OD3.0
Exposure time:	100µs (lowest value)
Gain:	1 (lowest value)
Maximum beam power:	<1W

**A higher power level is possible with additional ND filter:**

Optical density	Higher limit
OD 1.0	10 x Saturation limit
OD 2.0	100 x Saturation limit
OD 3.0	1000 x Saturation limit
OD 4.0	10000 x Saturation limit

**By longer exposure times a lower power level is apply:**

Exposure time	Lower limit	
100µs	See chart for cw saturation limit	
1ms	0.1 x Saturation limit	
10ms	0.01 x Saturation limit	Only for cw laser!
100ms	0.001 x Saturation limit	
1000ms	0.0001 x Saturation limit	

**Max. pulse repetition rate / pulse length for single pulse measurement:**

See chart for pulse saturation limit

Exposure time	Pulse repetition rate / pulse length	
100µs	10kHz / <100µs	
1ms	1kHz / <1ms	
10ms	100Hz / <10ms	Only for pulsed laser!
100ms	10Hz / <100ms	
1000ms	1Hz / <1000ms	