

ASNT5152-PQC 17Gbps 2:1 High Isolation Selector

- High speed broadband 2:1 high isolation selector gate.
- Exhibits low jitter and limited temperature variation over industrial temperature range.
- Up to 1.0GHz of bandwidth for selector input.
- Ideal for high speed proof-of-concept prototyping.
- Fully differential input and output buffers with on-chip 50Ω termination.
- CML output interface with 400mV single-ended swing.
- Single ±3.3V power supply.
- Power consumption: 315mW.
- Fabricated in SiGe for high performance, yield, and reliability.
- Standard MLF/QFN 24-pin package.

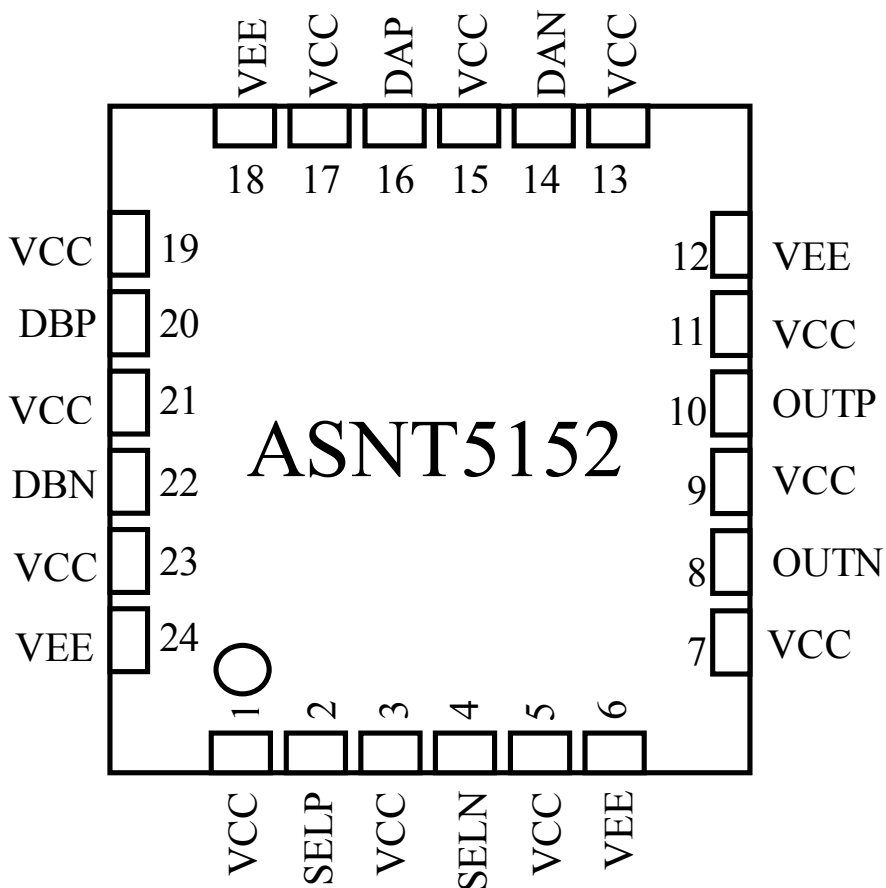

DESCRIPTION

The temperature stable and broadband ASNT5152-PQC SiGe IC is a high isolation selector switch that is intended for use in high-speed measurement / test equipment. ASNT5152-PQC can route one of its data inputs to its output while effectively blocking the other data input with high isolation. Selection of a specific data input is achieved through appropriate up to 1.0GHz external biasing of the selector signal inputs. The part's I/Os support the CML logic interface with on chip 50Ω termination and may be used differentially, AC/DC coupled, single-ended, or in any combination. It operates from a single ±3.3V power supply.

FUNCTIONAL BLOCK DIAGRAM

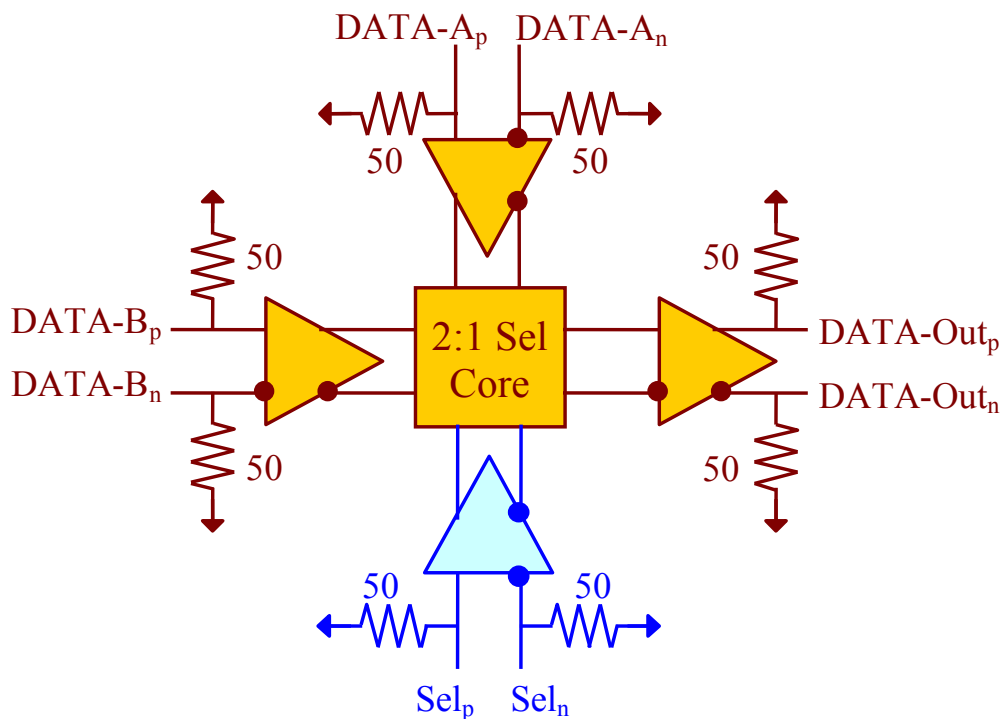

TERMINAL FUNCTIONS

vcc	1,3,5,7,9,11 13,15,17,19,21,23	PS	Power Supply: 3.3V / 0V
vee	6,12,18,24	PS	Power Supply: 0V / -3.3V
dbp	20	Input	Differential CML high-speed data signal inputs
dbn	22		
dap	16	Input	Differential CML high-speed data signal inputs
dan	14		
selp	2	Input	Differential CML selector signal inputs
seln	4		
outp	10	Output	Differential CML high-speed data signal outputs
outn	8		



ELECTRICAL CHARACTERISTICS

PARAMETER	MIN	TYP	MAX	UNIT	COMMENTS
VEE	-3.1	0.0 / -3.3	-3.5	V	±6%
VCC	3.1	3.3 / 0.0	3.5	V	±6%
IEE		95		mA	
Power		315		mW	
Junction Temp.	-25	50	125	°C	
Input Data (d)					
Data rate	DC		17	Gbps	
CM Level	Vcc-0.8	Vcc-0.3	Vcc+0.3	V	
SE Swing	50	300	800	mV	Peak-to-peak
Input Select (sel)					
Frequency	DC		1.0	GHz	
CM Level	Vcc-0.8	Vcc-0.3	Vcc+0.3	V	
SE Swing	50	300	800	mV	Peak-to-peak
Duty Cycle	40%	50%	60%		
Output Data (out)					
Data rate	0.0		17	Gbps	
CM Level	Vcc-0.3	Vcc-0.2	Vcc-0.1	V	
SE Swing	380	400	420	mV	Peak-to-peak
Rise/Fall Times	15	17	19	ps	20%-80%
Additive Jitter			<1	ps	Peak-to-peak

PACKAGE INFORMATION

The chip is packaged in a standard 24-pin QFN package. The package's mechanical information is available on the company's [website](#).